



**TRENCH SAFETY**

2731 Huffman Mill Road Burlington, NC 27215 336-516-8011

[ironlot.com](http://ironlot.com)

**Tabulated Data**

**Pacific Shoring MAPS**

**Modular Aluminum Panel System**

Supplied By: Iron Lot, LLC

# MODULAR ALUMINUM PANEL SYSTEM - YELLOW

TABULATED DATA  
Effective May 27<sup>th</sup>, 2025

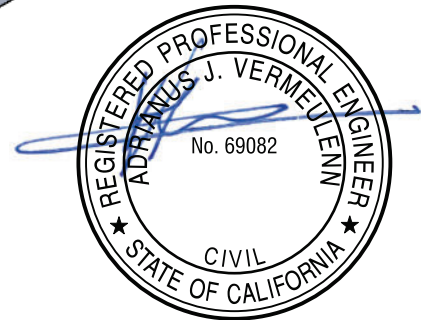
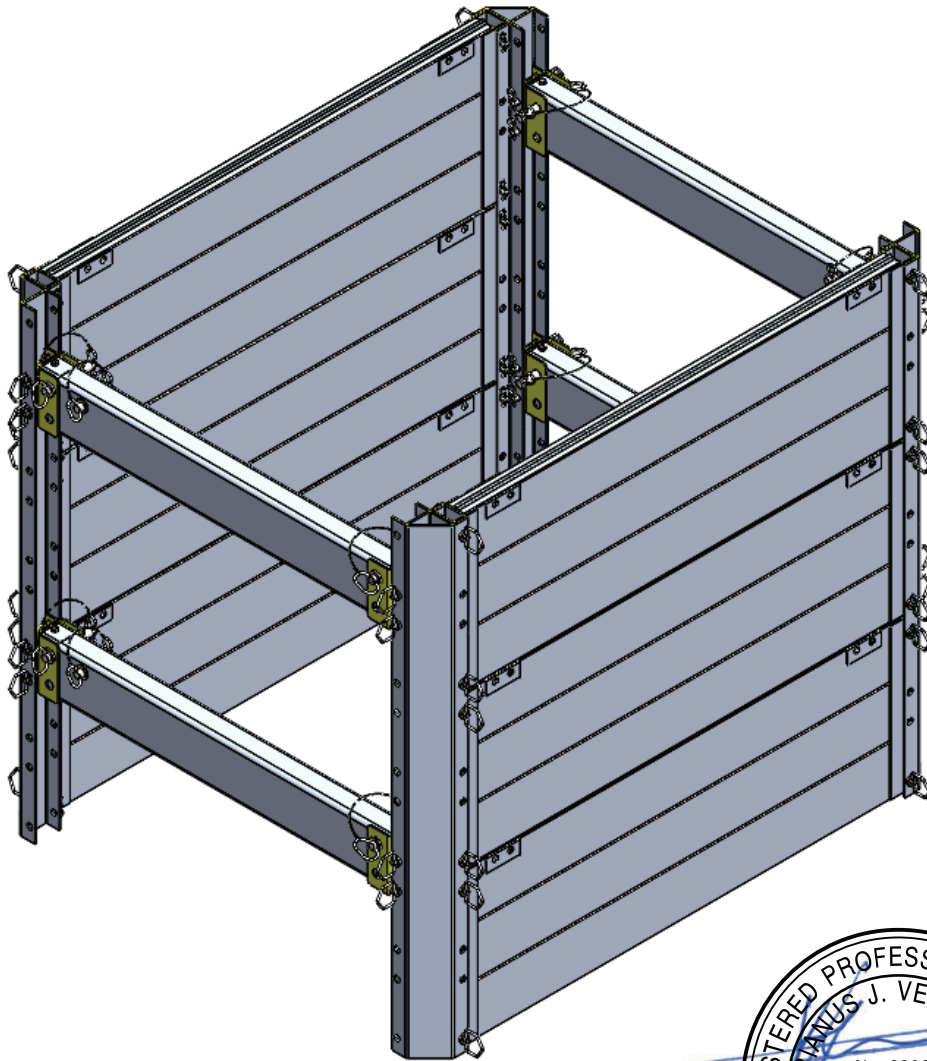

Signed 5/27/2025

---

## Contents

Description.....	2
General Information for use of Pacific Shoring Products Yellow MAPS .....	3
Classification of Soil Types .....	4
Determining Yellow MAPS Configurations.....	5
Yellow MAPS Components & Sizing.....	6
Geometric Properties for Engineering Design.....	7
Allowable Depths for Yellow MAPS .....	8
Allowable Corner Post Spans .....	9
Allowable Spreader Spans .....	12
Allowable Depths for Splice Kit Usage.....	13
Allowable Depths for High Clearance Arches.....	14
Yellow Modular Aluminum Panel System Installation and Removal.....	15
Safe Handling and Use of Yellow Modular Aluminum Panel Systems .....	15

## Description

The Pacific Shoring Products Yellow Modular Aluminum Panel System is a versatile aluminum trench shoring system designed for maximum adaptability in the field. It features 2.8" x 8" tongue-and-groove panels, corner posts, and an end strut system, enabling assembly in 2-sided, 3-sided, or 4-sided configurations. All components, panels, posts, and struts are secured using pin connections, allowing for quick on-site construction, adjustment, and disassembly.

Panel lengths range from 2 ft. to 16 ft, while corner posts are available in lengths from 2 ft. to 12 ft. The system is stackable and suitable for trench depths of up to 25 ft. Compatible strut options include hand-adjustable struts, static struts, and hydraulic struts capable of expanding to a maximum width of 12 ft. In a 4-sided layout, the system can accommodate dimensions up to 16 ft. x 16 ft.

The Modular Aluminum Panel System can be deployed in either a static or dynamic shoring configuration. In a static configuration, the system provides structural support without direct contact between the shield walls and the excavation sides. In contrast, the dynamic configuration uses pressurized shield walls to engage the surrounding soil, inducing soil arching and transferring pressure to the corners. This reduces wall loading, allows for slightly longer spans, and minimizes the risk of wall collapse and damage to adjacent utilities.

Ideal for utility work, the system excels in environments with constantly changing excavation conditions and geometry. Components are lightweight and manageable by a single person, and assembled units can be positioned using standard backhoes. The modular design allows for easy transport on standard trucks and quick setup as site conditions evolve.

## General Information for use of Pacific Shoring Products Yellow MAPS

1. The Yellow Modular Aluminum Panel Systems tabulated here is based on requirements of Federal OSHA 29CFR, Part 1926, Subpart P-Excavations, and Trenches.

**1926.652(c)(2)**-Option (2) - Designs Using Manufacturer's Tabulated Data.

1926.652(c)(2)(i) -Design of support systems, shield systems, or other protective systems that are drawn from manufacturer's tabulated data shall be in accordance with all specifications, recommendations, and limitations issued or made by the manufacturer.

All provisions of Subpart P apply when utilizing this tabulated data. The contractor's competent person shall use this data to select allowable trench depth, box wall, and strut configuration. The competent person utilizing this tabulated data shall be experienced and knowledgeable of all requirements of Subpart P, and trained in the use and safety procedures for shoring box applications.

2. Use of this tabulated data is dependent on first classifying the soil in accordance with OSHA Appendix A, Soil Classification. Classification shall be just prior to installing shoring box. Soil conditions may change at a later date and require reevaluation of the strength and allowable depth.
3. Modular aluminum buildable boxes are tabulated based on the effect of a 20,000 lb. surcharge load set back 2 ft. from the edge of the trench and the equivalent weight effect of the OSHA soil type, see classification of soil types, 2.
4. The depth and spacing given in **Tables 1-1 through 5-1** govern the use of Pacific Shoring Products Yellow Modular Aluminum Panel System and not tabulations given by other manufacturers. This tabulated data applies to buildable boxes manufactured by Pacific Shoring Products, LLC; however, all parts are interchangeable with Speed-Shore Modular Aluminum Panel Shields, "MAPS". Speed-Shore MAPS parts may be interchanged and used with Pacific Shoring Buildable Boxes under this tabulated data. Any alterations to the boxes or variance from this tabulated data shall be indicated in a site-specific plan prepared and approved by a registered professional engineer.
5. Faces of excavations shall be vertical and the shoring walls shall be within 6" of the excavation walls.
6. Yellow Modular Aluminum Panel Systems may be stacked or longitudinally connected.
7. Yellow Modular Aluminum Panel Systems shall be installed and removed from outside the trench, **see installation and removal procedure.**
8. The competent person shall continually monitor the shored excavation for changed conditions such as water seepage, soil movement cracks at the surface, sloughing or raveling, proper surcharge load weight less than 20,000 lbs. and setback a minimum of 2 ft. that may damage the shores.
9. Workers shall always enter, exit, and work inside the shored area of the trench.
10. Yellow Modular Aluminum Panel Systems may be stacked as long as they are pinned together.
11. Yellow Modular Aluminum Panel Systems may be set a maximum of 2 ft. from the bottom of the excavation. The trench depth is considered to be the full distance to the bottom of the excavation.

---

## Classification of Soil Types

1. Soil classification shall be in accordance with OSHA Appendix A and classified just prior to installing Yellow Modular Aluminum Panel Systems. Soil conditions may change at a later date and require the competent person to check soil conditions periodically and adjust accordingly.

2. The equivalent weight of OSHA soil types\* is assumed to be as follows:

- OSHA Type "A" Soil                      25 PSF per ft of depth
- OSHA Type "B" Soil                      45 PSF per ft of depth
- Type "C-60" Soil                         60 PSF per ft of depth\*\*
- OSHA Type "C" Soil                      80 PSF per ft of depth

\* These equivalent weights were adapted from OSHA 1926 Subpart P App C, Timber Shoring for Trenches, Tables C-1.1, C-1.2, and C-1.3

\*\* Type C-60 soil is not identified or classified in OSHA Appendix A.

3. Type C-60 soil is soil that does not qualify as OSHA Type A, or Type B, can be cut with vertical walls and will stand up long enough to safely insert and pressurize the hydraulic system.

4. Yellow Modular Aluminum Panel Systems may be used in C-80 soil provided they are dug into the excavation and not driven into the soil.

## Determining Yellow MAPS Configurations

Shoring use and configurations shall be determined by the user (employer and designated competent person).

The following steps are necessary to properly configure and construct a Yellow Modular Aluminum Panel System:

1. Define soil type in accordance with OSHA Appendix A.
2. Determine surcharge loading. All shoring equipment is designed for a maximum of a 20,000 lb. surcharge load set back 2 ft. from the edge of the trench. Larger loads shall be set back further or reduced. The competent person shall have training and knowledge in proper determination of surcharge loads.
3. Determine length, width, and depth of shoring requirement.
4. Determine existing facilities and depths that they will enter into the shoring configuration.
5. Determine depths, locations, and clearance requirements of facilities that will be constructed inside the shoring.
6. Determine components of the Yellow Modular Aluminum Panel System needed to fit the requirements of the job site. These components will at a minimum consist of:
  - Modular Panels.
  - Corner Posts.
  - Steel Adjustable Spreaders for 2 and 3-sided configurations.
  - Connecting Pins.
7. Determine allowable depths and settings for components as follows:
  - a) Modular Panels - **Table 1-1. - Allowable Depth for Modular Aluminum Panel Systems**
  - b) Corner Posts - **Table 2-2. through Table 2-16. - Allowable Corner Post Spans.**  
Corner posts have an allowable cantilever span and allowable spreader spacing span based on the depth of the excavation. These tables apply to hydraulic power struts, steel adjustable spreaders, and screw jack struts.
  - c) Adjustable Spreaders - **Table 3-1. - Allowable Spreader Spans.**
  - d) Splice Kits – **Table 4-1. – Allowable Depth Ratings.**
  - e) High Clearance Arches – **Table 5-1. – Allowable Depth Ratings.**
8. Determine approximate shoring system weight before rigging.

Note. Rigging equipment and connections should have a 5:1 factor of safety.

**Yellow MAPS Components & Sizing**

Yellow Modular Panels	
Size	Weight (lbs.)
2' x 2'	35.00
2' x 3'	50.61
2' x 4'	65.11
2' x 5'	79.60
2' x 6'	94.09
2' x 7'	108.59
2' x 8'	123.08
2' x 10'	152.07
2' x 12'	181.05
2' x 13'	195.54
2' x 14'	210.04
2' x 16'	239.03
2' x 14' - HD	264.47
2' x 16' - HD	293.46

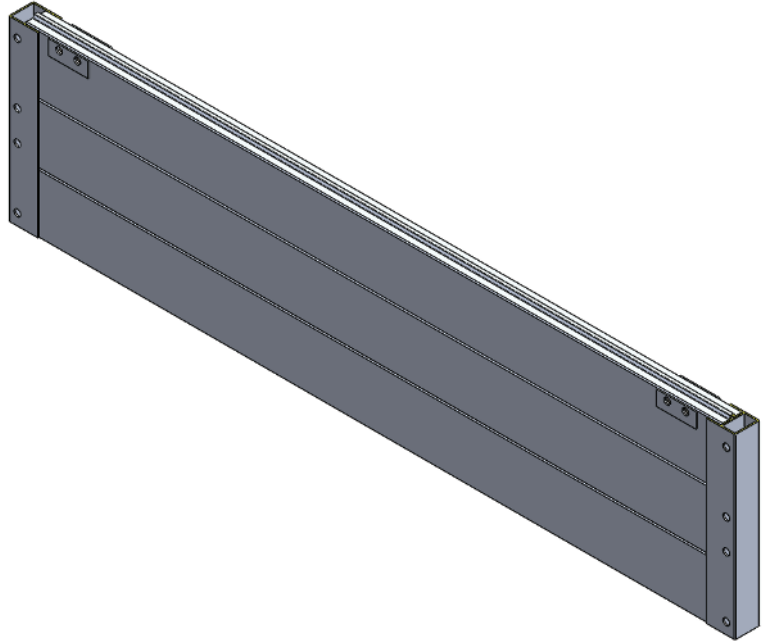

Yellow Angled Corner Posts	
Size	Weight (lbs.)
2'	12.10
4'	24.20
6'	36.31
8'	48.41
10'	60.51
12'	72.61

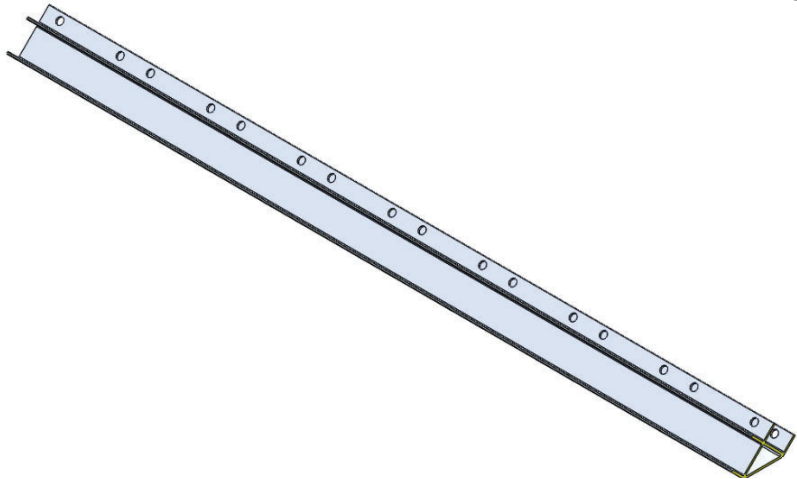

Yellow Adjustable Spreaders	
Size	Weight (lbs.)
17-23	22.81
21-30	27.72
27-36	37.03
35-48	46.85
40-60	52.95
52-84	67.61
60-96	77.48
72-120	92.15
108-144	137.18

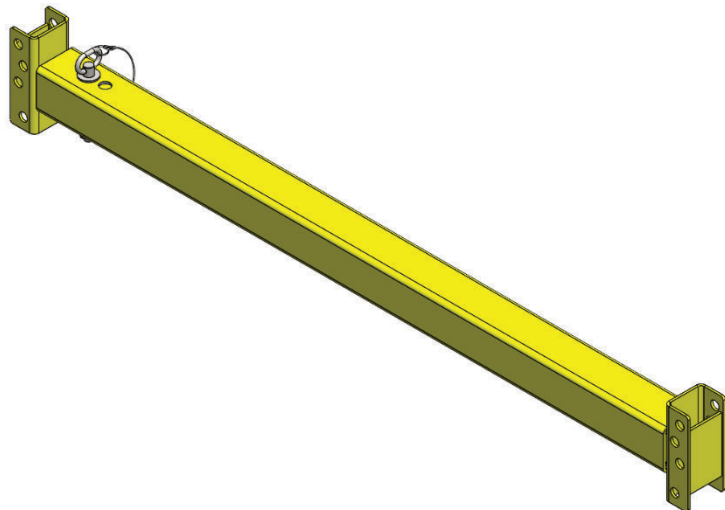

**Geometric Properties for Engineering Design**

**Materials**

Extruded Aluminum 6061-T6  
 Ultimate Tensile Strength  $F_{tu} = 45,000$  psi  
 Tensile Yield Strength  $F_{ty} = 40,000$  psi  
 Modulus of Elasticity = 10,000 ksi

Extruded Aluminum 6005A-T61  
 Ultimate Tensile Strength  $F_{tu} = 45,000$  psi  
 Tensile Yield Strength  $F_{ty} = 40,000$  psi  
 Modulus of Elasticity = 10,000 ksi

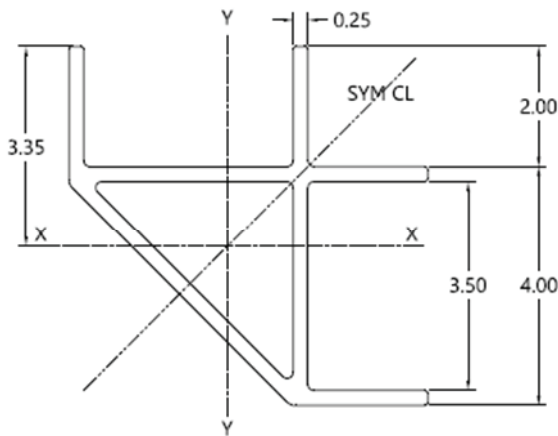

**CORNER POST**  
 AREA = 5.11 IN<sup>2</sup>  
 WEIGHT = 6.32 LBS/FT  
 MOMENT OF INERTIA = 8.58 IN<sup>4</sup>  
 SECTION MODULUS = 2.56 IN<sup>3</sup>

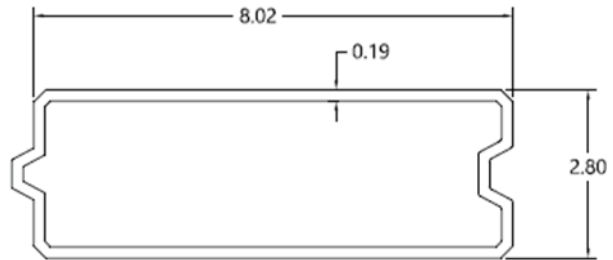

**BUILDABLE BOX PANEL**  
 AREA = 4.63 IN<sup>2</sup>  
 WEIGHT = 4.84 LBS/FT  
 MOMENT OF INERTIA = 5.50 IN<sup>4</sup>  
 SECTION MODULUS = 3.93 IN<sup>3</sup>

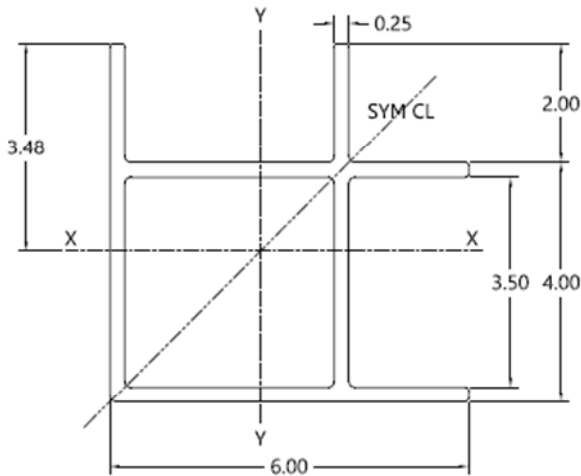

**SQUARE CORNER POST**  
 AREA = 5.77 IN<sup>2</sup>  
 WEIGHT = 6.93 LBS/FT  
 MOMENT OF INERTIA = 20.16 IN<sup>4</sup>  
 SECTION MODULUS = 5.79 IN<sup>3</sup>

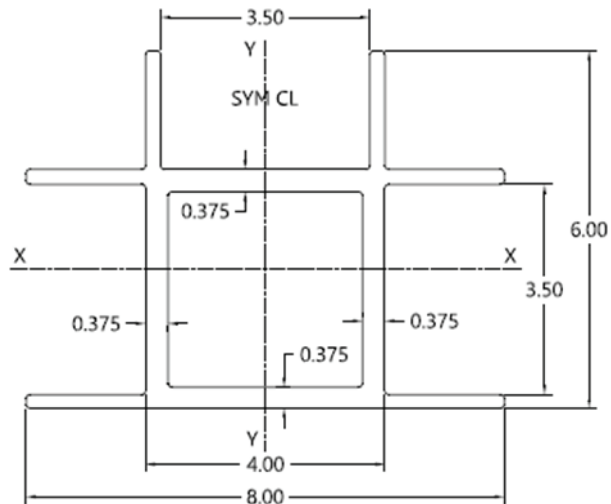

**MIDDLE T-POST**  
 AREA = 8.44 IN<sup>2</sup>  
 WEIGHT = 10.14 LBS/FT  
 MOMENT OF INERTIA = 27.29 IN<sup>4</sup>  
 SECTION MODULUS = 7.49 IN<sup>3</sup>

## Allowable Depths for Yellow MAPS

To determine the allowable depth rating for Yellow Modular Aluminum Panels, use **Table 1-1.** below.

Example - If the longest wall panel element is 12 ft. long and to be used in C-60 soil, from **Table 1-1.** the box may be used to a depth of 14 ft.

Table 1-1. Allowable Depths for Yellow Modular Aluminum Panels					
Panel Length (ft.)	Panel Capacity (PSF)	Allowable Depth (ft.)			
		OSHA Soil Type			
		A-25	B-45	C-60	C-80
2' x 3'	12,227	25	25	25	25
2' x 4'	6,878	25	25	25	25
2' x 5'	4,402	25	25	25	25
2' x 6'	3,057	25	25	25	25
2' x 7'	2,246	25	25	25	25
2' x 8'	1,840	25	25	25	23
2' x 10'	1,176	25	25	20	15
2' x 12'	816	25	18	14	10
2' x 13'	696	25	15	12	9
2' x 14'	600	24	13	10	8
2' x 16'	456	18	10	8	6
2' x 14' - HD	881	25	18	13	10
2' x 16' - HD	779	25	16	12	9

### Table 1-1. Notes

1. The panel assemblies are Pacific Shoring Products Modular Aluminum Panels as detailed in this tabulated data.
2. The longest modular panel wall in the constructed box shall govern the allowable depth given in **Table 1-1.**
3. Two- and three-sided boxes shall be strutted with spreaders and or arches.
4. See **Table 2-2. through Table 2-16.** for allowable corner post spans.
5. See **Table 3-1.** for allowable spreader spans.
6. If splice plates are to be used in any application, refer to the allowable depth ratings outlined in **Table 4-1.**
7. If high clearance arches are to be used in any application, refer to the allowable depth ratings outlined in **Table 5-1.**
8. The modular panel lengths are considered to be the overall dimension from **inside** of corner post to **inside** of opposite corner post.
9. Modular panels and adjustable spreaders must use a minimum of four connecting pins and keepers to secure them to the corner posts,
  - a. **(Two per side.)**
10. Tabulated depths are limited to 25 ft. deep. Additional depth may be achieved when the design is by a registered professional engineer.

### Allowable Corner Post Spans

On two- and three-sided boxes, use **Table 2-2. through Table 2-16.** to determine the allowable corner post cantilever and allowable strut spacing.

Example- If the longest wall panel element on a 3-sided box is 12 ft. long and to be used in C-60 soil at 14 ft. deep, from **Table 2-12**, the maximum corner post cantilever can be 2 ft. and the maximum strut spacing can be 4 ft.

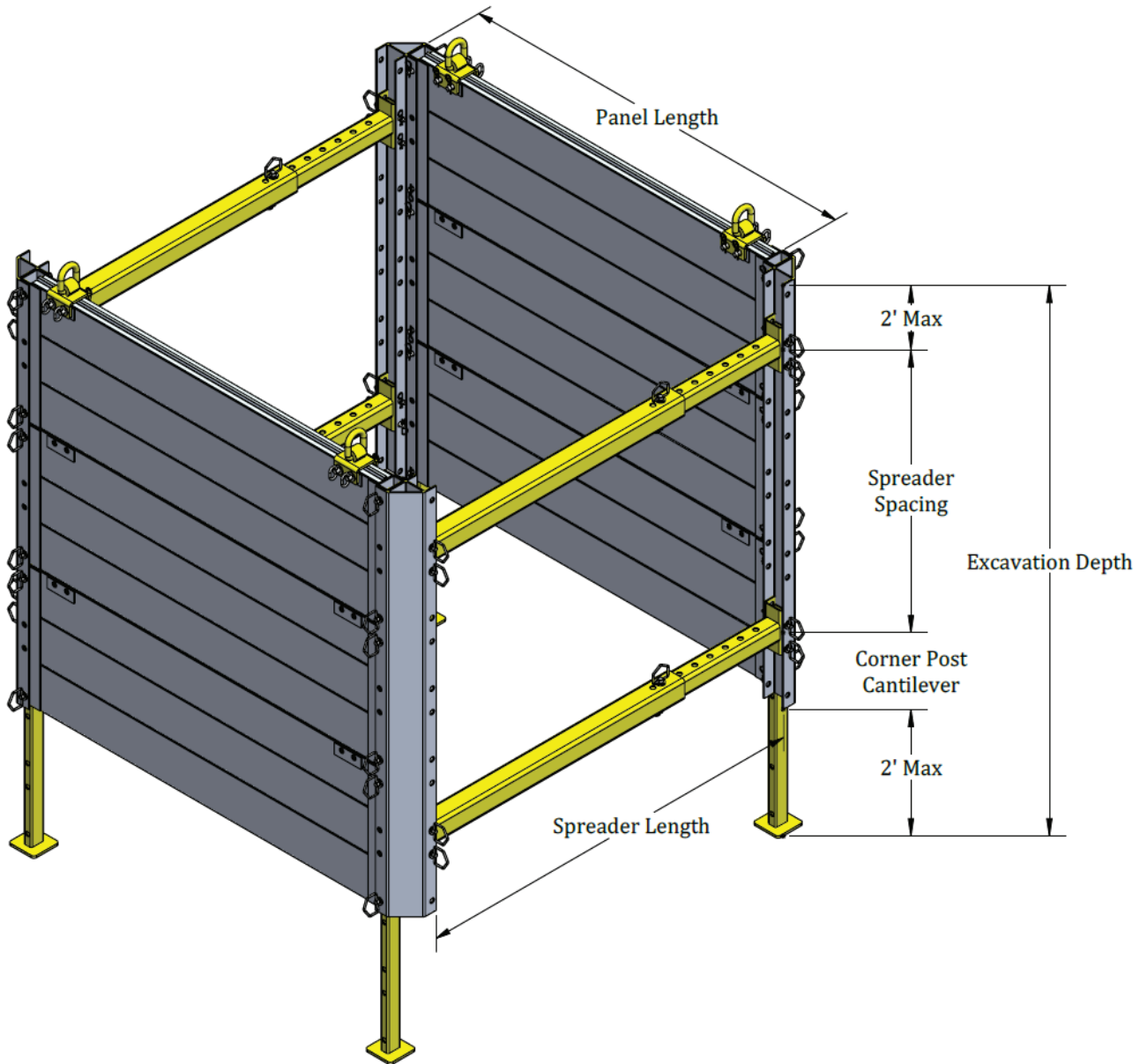

**Note.**

When modular aluminum panel systems are set in trenches that are sloped above, extend the box 18" above the hinge point. Slopes shall be in accordance with OSHA Appendix B sloping and benching.

Table 2-2. Allowable Corner Post Spans								
2' x 2' Panel Length								
Depth (ft.)	Corner Post Cantilever (ft.)				Spreader Spacing (ft.)			
	OSHA Soil Type				OSHA Soil Type			
	A-25	B-45	C-60	C-80	A-25	B-45	C-60	C-80
6	3.0	3.0	3.0	3.0	4.0	4.0	4.0	4.0
8	3.0	3.0	3.0	3.0	4.0	4.0	4.0	4.0
10	3.0	3.0	3.0	3.0	4.0	4.0	4.0	4.0
12	3.0	3.0	3.0	3.0	4.0	4.0	4.0	4.0
14	3.0	3.0	3.0	3.0	4.0	4.0	4.0	4.0
16	3.0	3.0	3.0	3.0	4.0	4.0	4.0	4.0
18	3.0	3.0	3.0	3.0	4.0	4.0	4.0	4.0
20	3.0	3.0	3.0	3.0	4.0	4.0	4.0	4.0
22	3.0	3.0	3.0	3.0	4.0	4.0	4.0	4.0
24	3.0	3.0	3.0	3.0	4.0	4.0	4.0	4.0
25	3.0	3.0	3.0	3.0	4.0	4.0	4.0	4.0

Table 2-3. Allowable Corner Post Spans								
2' x 3' Panel Length								
Depth (ft.)	Corner Post Cantilever (ft.)				Spreader Spacing (ft.)			
	OSHA Soil Type				OSHA Soil Type			
	A-25	B-45	C-60	C-80	A-25	B-45	C-60	C-80
6	3.0	3.0	3.0	3.0	4.0	4.0	4.0	4.0
8	3.0	3.0	3.0	3.0	4.0	4.0	4.0	4.0
10	3.0	3.0	3.0	3.0	4.0	4.0	4.0	4.0
12	3.0	3.0	3.0	3.0	4.0	4.0	4.0	4.0
14	3.0	3.0	3.0	3.0	4.0	4.0	4.0	4.0
16	3.0	3.0	3.0	3.0	4.0	4.0	4.0	4.0
18	3.0	3.0	3.0	3.0	4.0	4.0	4.0	4.0
20	3.0	3.0	3.0	3.0	4.0	4.0	4.0	4.0
22	3.0	3.0	3.0	3.0	4.0	4.0	4.0	4.0
24	3.0	3.0	3.0	3.0	4.0	4.0	4.0	4.0
25	3.0	3.0	3.0	3.0	4.0	4.0	4.0	4.0

Table 2-4. Allowable Corner Post Spans								
2' x 4' Panel Length								
Depth (ft.)	Corner Post Cantilever (ft.)				Spreader Spacing (ft.)			
	OSHA Soil Type				OSHA Soil Type			
	A-25	B-45	C-60	C-80	A-25	B-45	C-60	C-80
6	3.0	3.0	3.0	3.0	4.0	4.0	4.0	4.0
8	3.0	3.0	3.0	3.0	4.0	4.0	4.0	4.0
10	3.0	3.0	3.0	3.0	4.0	4.0	4.0	4.0
12	3.0	3.0	3.0	3.0	4.0	4.0	4.0	4.0
14	3.0	3.0	3.0	3.0	4.0	4.0	4.0	4.0
16	3.0	3.0	3.0	3.0	4.0	4.0	4.0	4.0
18	3.0	3.0	3.0	3.0	4.0	4.0	4.0	4.0
20	3.0	3.0	3.0	3.0	4.0	4.0	4.0	4.0
22	3.0	3.0	3.0	3.0	4.0	4.0	4.0	4.0
24	3.0	3.0	3.0	3.0	4.0	4.0	4.0	4.0
25	3.0	3.0	3.0	3.0	4.0	4.0	4.0	4.0

Table 2-5. Allowable Corner Post Spans								
2' x 5' Panel Length								
Depth (ft.)	Corner Post Cantilever (ft.)				Spreader Spacing (ft.)			
	OSHA Soil Type				OSHA Soil Type			
	A-25	B-45	C-60	C-80	A-25	B-45	C-60	C-80
6	3.0	3.0	3.0	3.0	4.0	4.0	4.0	4.0
8	3.0	3.0	3.0	3.0	4.0	4.0	4.0	4.0
10	3.0	3.0	3.0	3.0	4.0	4.0	4.0	4.0
12	3.0	3.0	3.0	3.0	4.0	4.0	4.0	4.0
14	3.0	3.0	3.0	2.9	4.0	4.0	4.0	4.0
16	3.0	3.0	3.0	3.0	4.0	4.0	4.0	4.0
18	3.0	3.0	3.0	3.0	4.0	4.0	4.0	4.0
20	3.0	3.0	3.0	3.0	4.0	4.0	4.0	4.0
22	3.0	3.0	3.0	2.0	4.0	4.0	4.0	4.0
24	3.0	3.0	3.0	2.0	4.0	4.0	4.0	4.0
25	3.0	3.0	3.0	2.0	4.0	4.0	4.0	4.0

Table 2-6. Allowable Corner Post Spans								
2' x 6' Panel Length								
Depth (ft.)	Corner Post Cantilever (ft.)				Spreader Spacing (ft.)			
	OSHA Soil Type				OSHA Soil Type			
	A-25	B-45	C-60	C-80	A-25	B-45	C-60	C-80
6	3.0	3.0	3.0	3.0	4.0	4.0	4.0	4.0
8	3.0	3.0	3.0	3.0	4.0	4.0	4.0	4.0
10	3.0	3.0	3.0	3.0	4.0	4.0	4.0	4.0
12	3.0	3.0	3.0	3.0	4.0	4.0	4.0	4.0
14	3.0	3.0	3.0	3.0	4.0	4.0	4.0	4.0
16	3.0	3.0	3.0	3.0	4.0	4.0	4.0	4.0
18	3.0	3.0	3.0	3.0	4.0	4.0	4.0	4.0
20	3.0	3.0	3.0	2.0	4.0	4.0	4.0	4.0
22	3.0	3.0	3.0	2.0	4.0	4.0	4.0	4.0
24	3.0	3.0	2.0	2.0	4.0	4.0	4.0	4.0
25	3.0	3.0	2.0	2.0	4.0	4.0	4.0	4.0

Table 2-7. Allowable Corner Post Spans								
2' x 7' Panel Length								
Depth (ft.)	Corner Post Cantilever (ft.)				Spreader Spacing (ft.)			
	OSHA Soil Type				OSHA Soil Type			
	A-25	B-45	C-60	C-80	A-25	B-45	C-60	C-80
6	3.0	3.0	3.0	3.0	4.0	4.0	4.0	4.0
8	3.0	3.0	3.0	3.0	4.0	4.0	4.0	4.0
10	3.0	3.0	3.0	3.0	4.0	4.0	4.0	4.0
12	3.0	3.0	3.0	3.0	4.0	4.0	4.0	4.0
14	3.0	3.0	3.0	3.0	4.0	4.0	4.0	4.0
16	3.0	3.0	3.0	2.0	4.0	4.0	4.0	4.0
18	3.0	3.0	3.0	2.0	4.0	4.0	4.0	4.0
20	3.0	3.0	2.0	2.0	4.0	4.0	4.0	4.0
22	3.0	3.0	2.0	2.0	4.0	4.0	4.0	4.0
24	3.0	3.0	2.0	2.0	4.0	4.0	4.0	4.0
25	3.0	3.0	2.0	2.0	4.0	4.0	4.0	4.0

**Table 2-8. Allowable Corner Post Spans**  
2' x 8' Panel Length

Depth (ft.)	Corner Post Cantilever (ft.)				Spreader Spacing (ft.)			
	OSHA Soil Type				OSHA Soil Type			
	A-25	B-45	C-60	C-80	A-25	B-45	C-60	C-80
6	3.0	3.0	3.0	3.0	4.0	4.0	4.0	4.0
8	3.0	3.0	3.0	3.0	4.0	4.0	4.0	4.0
10	3.0	3.0	3.0	3.0	4.0	4.0	4.0	4.0
12	3.0	3.0	3.0	3.0	4.0	4.0	4.0	4.0
14	3.0	3.0	3.0	2.0	4.0	4.0	4.0	4.0
16	3.0	3.0	3.0	2.0	4.0	4.0	4.0	4.0
18	3.0	3.0	2.0	2.0	4.0	4.0	4.0	4.0
20	3.0	3.0	2.0	2.0	4.0	4.0	4.0	4.0
22	3.0	2.0	2.0	2.0	4.0	4.0	4.0	4.0
24	3.0	2.0	2.0	2.0	4.0	4.0	4.0	3.0
25	3.0	2.0	2.0	2.0	4.0	4.0	4.0	3.0

**Table 2-10. Allowable Corner Post Spans**  
2' x 10' Panel Length

Depth (ft.)	Corner Post Cantilever (ft.)				Spreader Spacing (ft.)			
	OSHA Soil Type				OSHA Soil Type			
	A-25	B-45	C-60	C-80	A-25	B-45	C-60	C-80
6	3.0	3.0	3.0	3.0	4.0	4.0	4.0	4.0
8	3.0	3.0	3.0	3.0	4.0	4.0	4.0	4.0
10	3.0	3.0	3.0	2.0	4.0	4.0	4.0	4.0
12	3.0	3.0	3.0	2.0	4.0	4.0	4.0	4.0
14	3.0	3.0	2.0	2.0	4.0	4.0	4.0	4.0
16	3.0	3.0	2.0	2.0	4.0	4.0	4.0	4.0
18	3.0	2.0	2.0	2.0	4.0	4.0	4.0	4.0
20	3.0	2.0	2.0	2.0	4.0	4.0	4.0	3.0
22	3.0	2.0	2.0	2.0	4.0	4.0	4.0	3.0
24	3.0	2.0	2.0	2.0	4.0	4.0	4.0	3.0
25	3.0	2.0	2.0	2.0	4.0	4.0	3.0	3.0

**Table 2-12. Allowable Corner Post Spans**  
2' x 12' Panel Length

Depth (ft.)	Corner Post Cantilever (ft.)				Spreader Spacing (ft.)			
	OSHA Soil Type				OSHA Soil Type			
	A-25	B-45	C-60	C-80	A-25	B-45	C-60	C-80
6	3.0	3.0	3.0	3.0	4.0	4.0	4.0	4.0
8	3.0	3.0	3.0	2.0	4.0	4.0	4.0	4.0
10	3.0	3.0	3.0	2.0	4.0	4.0	4.0	4.0
12	3.0	3.0	2.0	2.0	4.0	4.0	4.0	4.0
14	3.0	3.0	2.0	2.0	4.0	4.0	4.0	4.0
16	3.0	2.0	2.0	2.0	4.0	4.0	4.0	3.0
18	3.0	2.0	2.0	2.0	4.0	4.0	4.0	3.0
20	3.0	2.0	2.0	2.0	4.0	4.0	4.0	3.0
22	3.0	2.0	2.0	2.0	4.0	4.0	3.0	2.0
24	3.0	2.0	2.0	2.0	4.0	4.0	3.0	2.0
25	3.0	2.0	2.0	1.0	4.0	4.0	3.0	2.0

**Table 2-13. Allowable Corner Post Spans**  
2' x 13' Panel Length

Depth (ft.)	Corner Post Cantilever (ft.)				Spreader Spacing (ft.)			
	OSHA Soil Type				OSHA Soil Type			
	A-25	B-45	C-60	C-80	A-25	B-45	C-60	C-80
6	3.0	3.0	3.0	2.0	4.0	4.0	4.0	4.0
8	3.0	3.0	3.0	2.0	4.0	4.0	4.0	4.0
10	3.0	3.0	2.0	2.0	4.0	4.0	4.0	4.0
12	3.0	3.0	2.0	2.0	4.0	4.0	4.0	4.0
14	3.0	2.0	2.0	2.0	4.0	4.0	4.0	3.0
16	3.0	2.0	2.0	2.0	4.0	4.0	4.0	3.0
18	3.0	2.0	2.0	2.0	4.0	4.0	4.0	3.0
20	3.0	2.0	2.0	2.0	4.0	4.0	3.0	2.0
22	3.0	2.0	2.0	2.0	4.0	4.0	3.0	2.0
24	2.0	2.0	2.0	1.0	4.0	4.0	3.0	2.0
25	2.0	2.0	2.0	1.0	4.0	3.0	3.0	2.0

**Table 2-14. Allowable Corner Post Spans**  
2' x 14' Panel Length (HD & Non-HD)

Depth (ft.)	Corner Post Cantilever (ft.)				Spreader Spacing (ft.)			
	OSHA Soil Type				OSHA Soil Type			
	A-25	B-45	C-60	C-80	A-25	B-45	C-60	C-80
6	3.0	3.0	3.0	3.0	4.0	4.0	4.0	4.0
8	3.0	3.0	3.0	2.0	4.0	4.0	4.0	4.0
10	3.0	3.0	2.0	2.0	4.0	4.0	4.0	4.0
12	3.0	2.0	2.0	2.0	4.0	4.0	4.0	4.0
14	3.0	2.0	2.0	2.0	4.0	4.0	4.0	3.0
16	3.0	2.0	2.0	2.0	4.0	4.0	4.0	3.0
18	3.0	2.0	2.0	2.0	4.0	4.0	3.0	3.0
20	3.0	2.0	2.0	2.0	4.0	4.0	3.0	2.0
22	2.0	2.0	2.0	1.0	4.0	4.0	3.0	2.0
24	2.0	2.0	2.0	1.0	4.0	3.0	3.0	2.0
25	2.0	2.0	2.0	1.0	4.0	3.0	2.0	2.0

**Table 2-16. Allowable Corner Post Spans**  
2' x 16' Panel Length (HD & Non-HD)

Depth (ft.)	Corner Post Cantilever (ft.)				Spreader Spacing (ft.)			
	OSHA Soil Type				OSHA Soil Type			
	A-25	B-45	C-60	C-80	A-25	B-45	C-60	C-80
6	3.0	3.0	2.0	2.0	4.0	4.0	4.0	4.0
8	3.0	2.0	2.0	2.0	4.0	4.0	4.0	3.0
10	3.0	2.0	2.0	2.0	4.0	4.0	3.0	3.0
12	3.0	2.0	2.0	2.0	4.0	3.0	3.0	3.0
14	3.0	2.0	2.0	1.0	4.0	3.0	3.0	2.0
16	2.0	2.0	2.0	1.0	3.0	3.0	2.0	2.0
18	2.0	2.0	2.0	1.0	3.0	3.0	2.0	2.0
20	2.0	2.0	1.0	1.0	3.0	3.0	2.0	1.0
22	2.0	2.0	1.0	1.0	3.0	2.0	2.0	1.0
24	2.0	2.0	1.0	1.0	3.0	2.0	2.0	1.0
25	2.0	2.0	1.0	1.0	3.0	2.0	2.0	1.0

**Table 2-2. through Table 2-16.** Notes

1. The upper most spreader element shall be placed no more than 2 ft. from the top of the corner post as seen in the diagram on page 9.
2. Always use a minimum of two struts per corner post.
  - a. 2 ft. stackers are an exception provided they are connected and secured using stacking pins and the appropriate hardware.
3. Short sectional corner posts up to 4 ft. in length shall have a strut top and bottom.
4. Long sectional corner posts from 6 ft. to 12 ft. in length shall have spreaders spaced as shown in **Table 2-2 through Table 2-16.**
5. Interpolation between tables is OK.
6. Two-, Three- and Four-sided **simple static** applications do not require continuous corner post so long as the stacked boxes are connected and secured using stacking pins and the appropriate hardware.
7. One-sided boxes shall have continuous corner post, for example an 8 ft. tall one-sided box must have an 8 ft. long corner posts.
  - a. Strut spacing shall be as shown in **Table 2-8.**
8. When using legs to raise the modular aluminum panel system 2 ft. from the bottom of the excavation, the corner post cantilever may not exceed 2 ft. giving a total clearance of 4 ft.

**Allowable Spreader Spans**

**Table 3-1.** gives the maximum allowable spreader length allowed for any modular aluminum panel system configuration. Longer lengths may be allowed as determined by a registered professional engineer.

Table 3-1. Allowable Spreader Spans	
Spreader Type	Spreader Length (ft.)
Adjustable Spreader (static)	12'
Power Strut (hydraulic)	12'



**Allowable Depths for Splice Kit Usage**

Table 4-1. Allowable Depths for Spliced Yellow Modular Aluminum Panels					
Panel Length (ft.)	Panel Capacity (PSF)	Allowable Depth (ft.)			
		OSHA Soil Type			
		A-25	B-45	C-60	C-80
2' x 3'	12,227	25	25	25	25
2' x 4'	6,878	25	25	25	25
2' x 5'	4,402	25	25	25	25
2' x 6'	3,057	25	25	25	25
2' x 7'	2,246	25	25	25	25
2' x 8'	1,840	25	25	25	23
2' x 10'	1,176	25	25	20	15
2' x 12'	816	25	18	14	10
2' x 13'	696	25	15	12	9
2' x 14'	600	24	13	10	8
2' x 16'	456	18	10	8	6
2' x 14' - HD	881	25	18	13	10
2' x 16' - HD	779	25	16	12	9

**Table 4-1. Notes**

1. Spliced panels can be any length to make up the spliced panel length.
2. Bolts and nuts must be minimum 3/4" ASTM A325 with washers both sides.
  - a. The hardware must be torqued to minimum 140 foot-pounds.
3. The spliced panel length rating strength is equivalent to the strength of a continuous panel of the same length.
4. Bolt heads may be on the inside or outside of the panel.
5. If HD Panels and Non-HD Panels are spliced together the lesser of the two depth ratings governs.

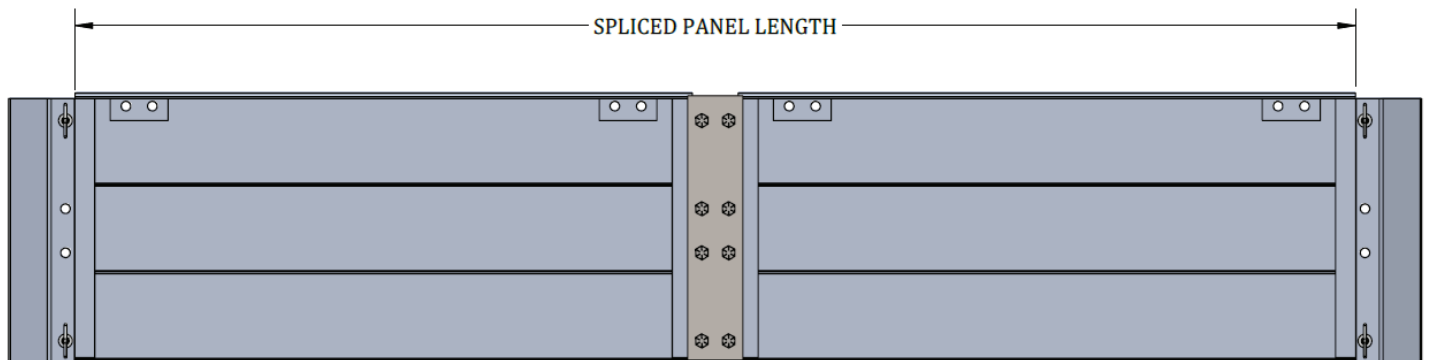

### Allowable Depths for High Clearance Arches

High Clearance Arches are used to achieve additional clearance below the strut. These arches can be used with modular boxes constructed 6 ft. and 8 ft high.

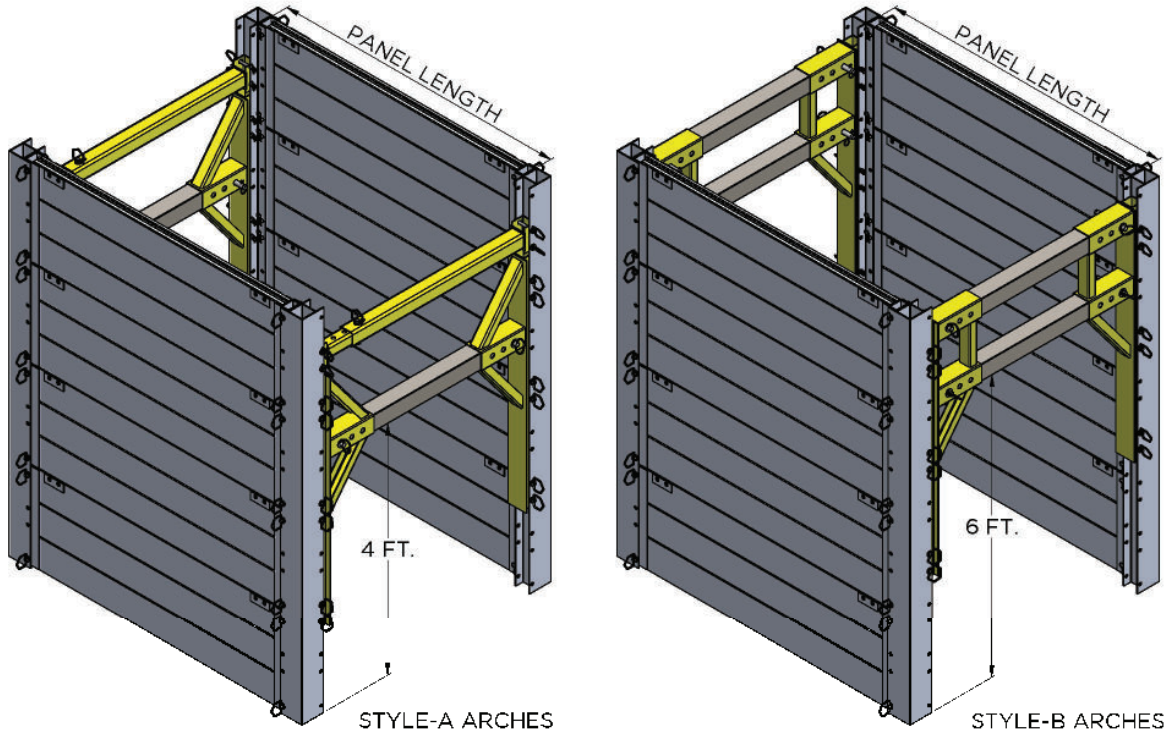

**Table 5-1. Allowable Depths For High Clearance Arches**

Panel Length (ft.)	Style-A Arch				Style-B Arch			
	Clearance = 4 ft.				Clearance = 6 ft.			
	OSHA Soil Type				OSHA Soil Type			
	A-25	B-45	C-60	C-80	A-25	B-45	C-60	C-80
2' x 2'	20	20	20	16	20	20	20	16
2' x 3'	20	20	20	16	20	20	20	16
2' x 4'	20	20	20	16	20	20	20	16
2' x 5'	20	20	20	16	20	20	18	16
2' x 6'	20	20	20	16	20	20	16	14
2' x 7'	20	20	20	16	20	18	16	12
2' x 8'	20	20	20	16	20	18	14	10
2' x 10'	20	20	18	14	14	14	10	8
2' x 12'	20	18	14	8	8	8	8	6
2' x 13'	20	15	11	7	7	7	6	6
2' x 14'	20	12	8	6	6	6	6	6
2' x 16'	16	8	6	N/A	N/A	N/A	N/A	N/A
2' x 14' - HD	20	12	8	6	6	6	6	6
2' x 16' - HD	16	8	6	N/A	N/A	N/A	N/A	N/A

**Table 5-1.** Notes

1. The corner posts must be continuous from bottom to top of modular box application
2. There must always be a single strut used on the same corner post set above the medium clearance arch.
3. On excavations to 10 ft. deep and maximum 10 ft. wide in A, B & C-60 soil, it is allowable to use sheet pile and timber lagging set against the spreaders at the ends.
4. Leg sets may not be used in conjunction with high clearance arches to raise the modular box application 2 ft. off the bottom of the excavation.
5. 4" x 4" x 3/16" A-500 GR-B structural steel square tubing shall be used as static arch spreaders.

## **Yellow Modular Aluminum Panel System Installation and Removal**

### **Installation Procedure**

Modular aluminum panel systems must be constructed prior to setting inside the trench.

- Step 1 Pin panels into corner posts. Assemble the system in a stable configuration starting at the corners and setting modular panels in opposite directions.
- Step 2 In two- and three-sided configurations pin the steel adjustable spreaders into the corner posts and adjust them to the proper length.
- Step 3 Lower the assembled system into the trench with the proper lifting equipment such as a backhoe, boom truck or crane.

### **Removal Procedure**

- Step 1 Remove the box using equipment operated from outside the trench. Workers are not allowed inside the box when it is being set, moved, or removed from the trench.

## **Safe Handling and Use of Yellow Modular Aluminum Panel Systems**

- When modular aluminum panel systems are set in trenches that are sloped above, extend the box 18" above the hinge point. Slopes shall be in accordance with OSHA Appendix B sloping and benching.
- When there is sloping beyond the top of the box depth of the excavation is limited to 20 ft. without a design by a registered engineer.
- Workers are not allowed inside the box when it is being set, moved, or removed from the trench.
- Provide safe access such as ladders for workers to enter and exit the shoring system.
- Use cables and slings for lifting that have a 5:1 factor of safety. A competent person is to determine the total lift weight.